

FORGED EYE BOLT WARNINGS AND APPLICATION INSTRUCTIONS

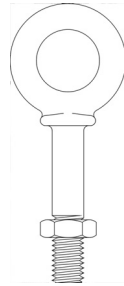

Regular Nut Eye Bolt
G-291



Shoulder Nut Eye Bolt
G-277



Machinery Eye Bolt
S-279 / M-279

Important Safety Information - Read & Follow

Inspection/Maintenance Safety:

- Always inspect eye bolt before use.
- Never use eye bolt that shows signs of wear or damage.
- Never use eye bolt if eye or shank is bent or elongated.
- Always be sure threads on shank and receiving holes are clean.
- Never machine, grind, or cut eye bolt.

Assembly Safety:

- Never exceed load limits specified in Table I & Table 2.
- Never use regular nut eye bolts for angular lifts.
- Always use shoulder nut eye bolts (or machinery eye bolts) for angular lifts.
- For angular lifts, adjust working load as follows:

Direction of Pull (in-line)	Adjusted Working Load
45 degrees	30% of rated working load
90 degrees	25% of rated working load

- Never undercut eye bolt to seat shoulder against the load.
- Always countersink receiving hole or use washer with sufficient I.D. to seat shoulder.
- Always screw eye bolt down completely for proper seating.
- Always tighten nuts securely against the load.

Size (in.)	Working Load Limit (lbs.)
1/4	650
5/16	1,200
3/8	1,550
1/2	2,600
5/8	5,200
3/4	7,200
7/8	10,600
1	13,300
1-1/8	15,000
1-1/4	21,000
1-1/2	24,000
1-3/4	34,000
2	42,000
2-1/2	65,000

WARNING

- Loads may slip or fall if proper eye bolt assembly and lifting procedures are not used.
- A falling load can seriously injure or kill.
- Read and understand both sides of these instructions, and follow all eye bolt safety information presented here.
- Read, understand, and follow information in diagrams and charts below before using eye bolt assemblies.

Shoulder Nut Eye Bolt — Installation for Angular Loading

- The threaded shank must protrude through the load sufficiently to allow full engagement of the nut.
- If the eye bolt protrudes so far through the load that the nut cannot be tightened securely against the load, use properly sized washers to take up the excess space BETWEEN THE NUT AND THE LOAD.
- Thickness of spacers must exceed this distance between the bottom of the load and the last thread of the eye bolt.
- Place washers or spacers between nut and load so that when the nut is tightened securely, the shoulder is secured flush against the load surface.

Metric Size	Working Load Limit - kg
m6	200
m8	400
m10	640
m12	1000
m16	1800
m20	2500
m24	4000
m27	5000
m30	6000
m36	8500
m42	14000
m48	17300
m64	29500

IMPORTANT - Read and understand these instructions before using eye bolts.

Regular Nut & Shoulder Nut Eye Bolt - Installation for In-line Loading

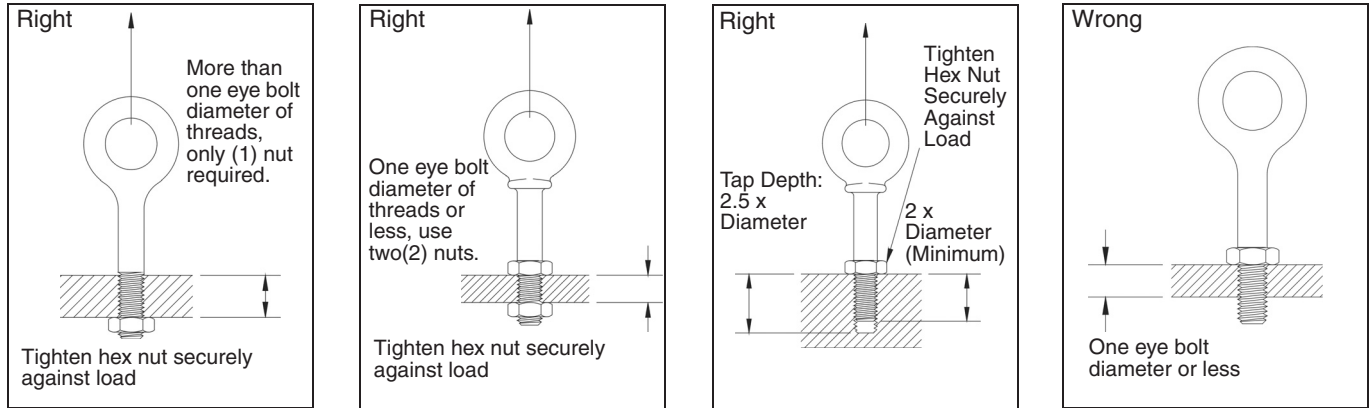

Operating Safety

- Always stand clear of load.
- Always lift load with steady, even pull – do not jerk.
- Always apply load to eye bolt in the plane of the eye – not at an angle.
- Never exceed the capacity of the eye bolt—see Table I & 2.
- When using lifting slings of two or more legs, make sure the loads in the legs are calculated using the angle from the vertical to the leg and properly size the shoulder nut or machinery eye bolt for the angular load.

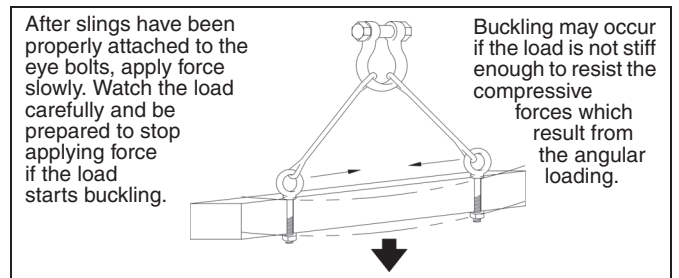
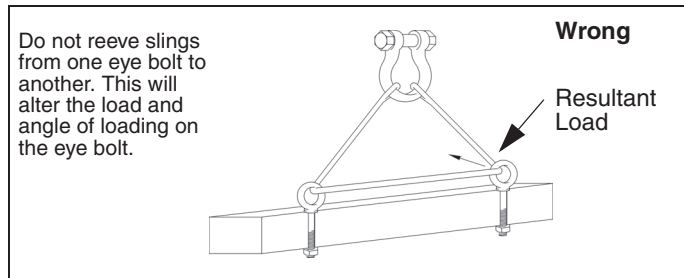

Machinery Eye Bolt - Installation for In-line & Angular Loading

These eye bolts are primarily intended to be installed into tapped holes.

1. After the loads on the eye bolts have been calculated, select the proper size eye bolt for the job.

For angular lifts, adjust working load as follows:

Direction of Pull	Adjusted Working Load
45 degrees	30% of rated working load
90 degrees	25% of rated working load

2. Drill and tap the load to the correct sizes to a minimum depth of one-half the eye bolt size beyond the shank length of the machinery eye bolt.
3. Thread the eye bolt into the load until the shoulder is flush and securely tightened against the load.
4. If the plane of the machinery eye bolt is not aligned with the sling line, estimate the amount of unthreading rotation necessary to align the plane of the eye properly. Remove the machinery eye bolt from the load and add shims (washers) of proper thickness to adjust the angle of the plane of the eye to match the sling line. Use Table 3 to estimate the required shim thickness for the amount of unthreading rotation required.

Eye Bolt Size (in.)	Shim Thickness Required to Change Rotation 90° (in.)	Eye Bolt Size (mm)	Shim Thickness Required to change Rotation 90° (mm)
1/4	.0125	M6	.25
5/16	.0139	M8	.31
3/8	.0156	M10	.38
1/2	.0192	M12	.44
5/8	.0227	M16	.50
3/4	.0250	M20	.62
7/8	.0278	M24	.75
1	.0312	M27	.75
1-1/8	.0357	M30	.88
1-1/4	.0357	M36	1.00
1-1/2	.0417	—	—
1-3/4	0.500	M42	1.13
2	.0556	M48	1.25
2-1/2	.0625	M64	1.50

