

Parts List for:

PE4004S-DAYCO
PE4004S50-DAYCO

MODEL B ELECTRIC HYDRAULIC PUMP

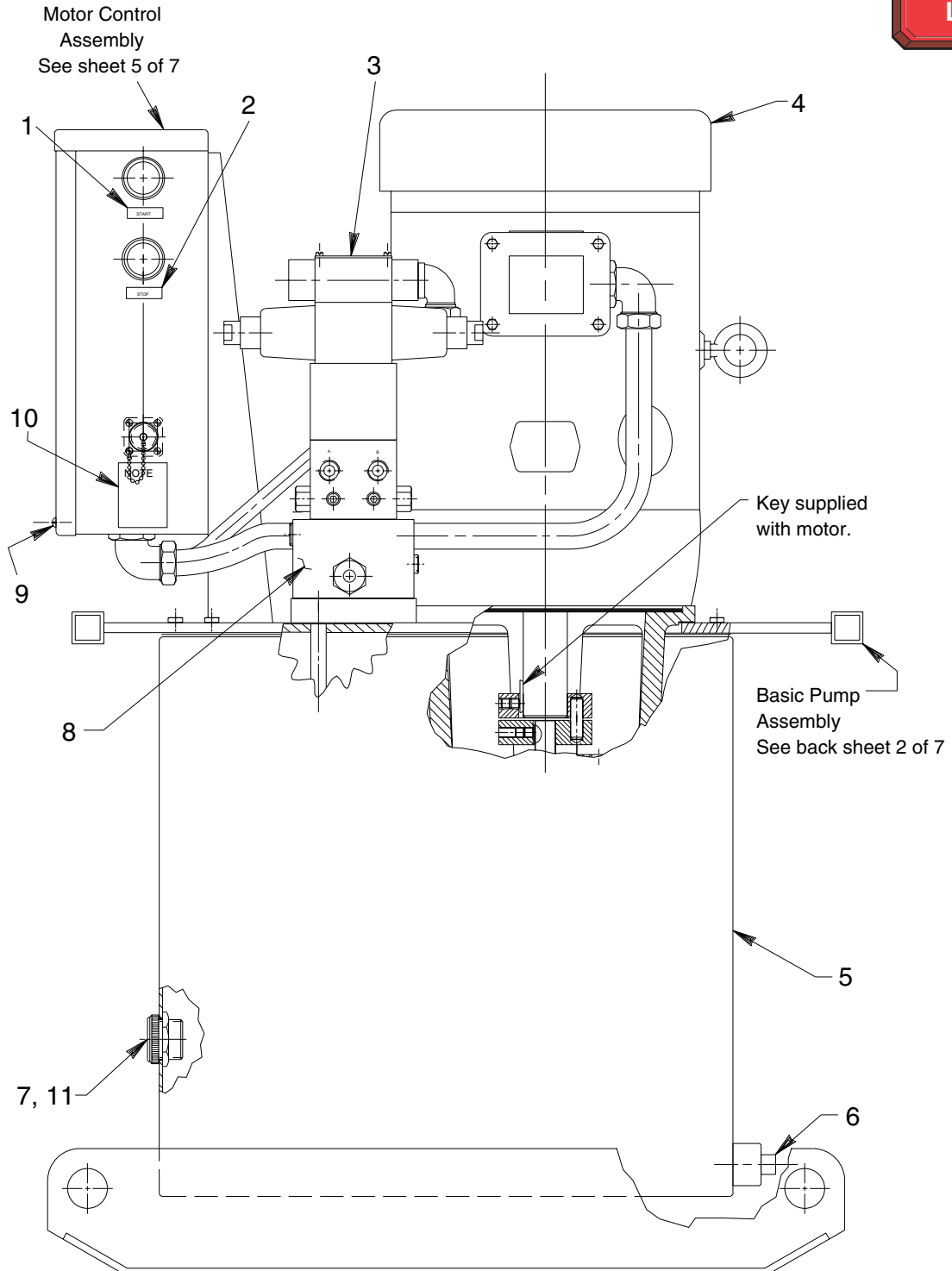

Item No.	Part No.	No. Req'd	Description
1	203808	1	Decal (Start)
2	203769	1	Decal (Stop)
4	19326WH2	1	Electric Motor (10 H.P.; For PE4004S-DAYCO)
	39537WH2	1	Electric Motor (10 H.P.; For PE4004S50-DAYCO)
5	60430BL2	1	Reservoir
6	11049	1	Drain Plug (3/4 NPTF)
7	17586	1	Sight Gauge
8	204265	1	Drain Tube
9	9513	1	Valve (3 pos., 4-way Solenoid; See Form 101653)
10	204015	1	Decal (Thermal Protection)
11	253300	1	Seal Washer

PARTS INCLUDED BUT NOT SHOWN

200188	1	Warning Decal
17419	1	Decal



Note: Shaded areas reflect last revision(s) made to this form.

HYDRAULIC SCHEMATIC

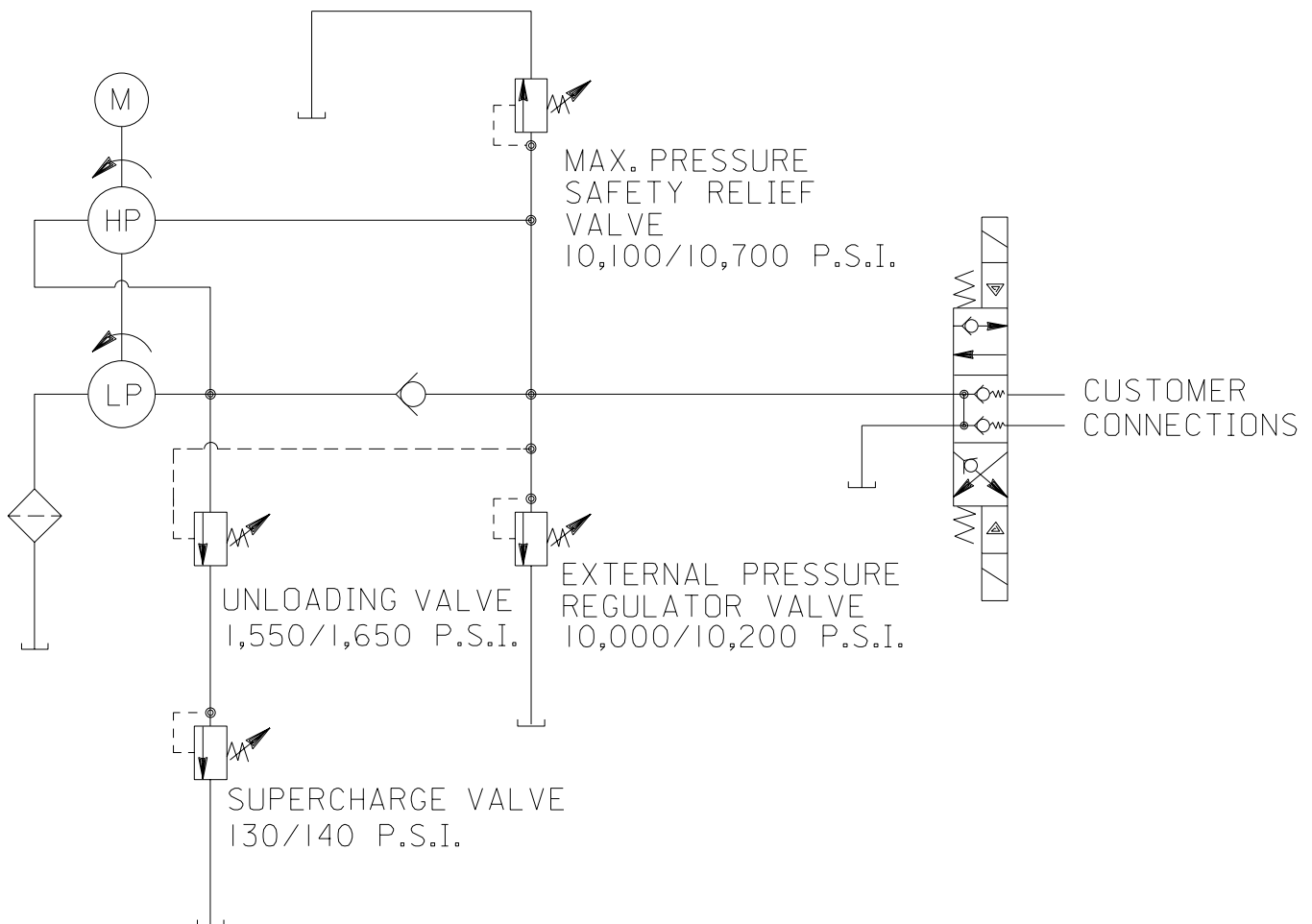

PUMP TOP VIEW

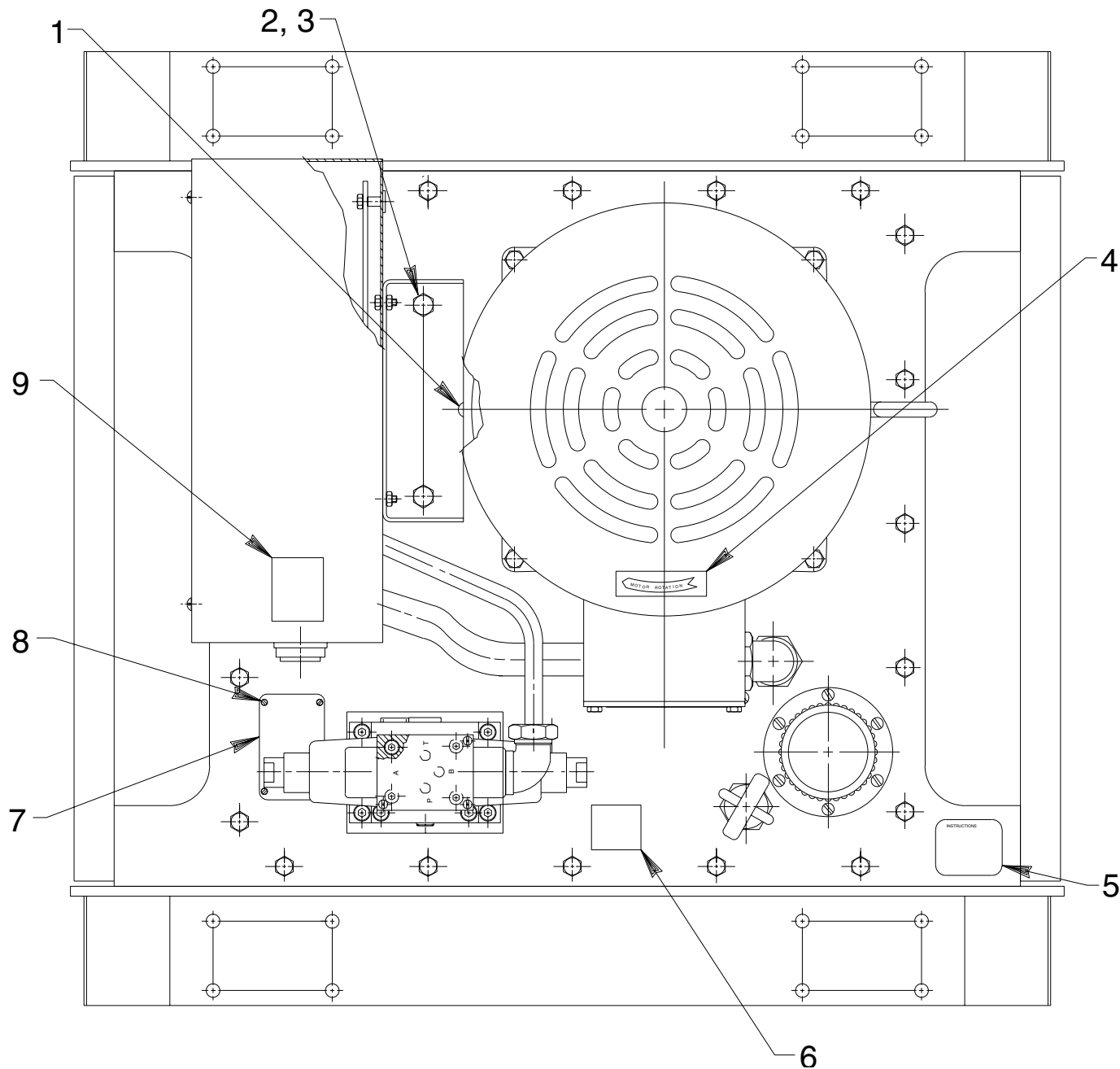

Item No.	Part No.	No. Req'd	Description
1	10820	1	Drive Screw
2	15273	2	Hex Hd. Cap Screw (5/16-18 x 1/2 Lg.)
3	10246	2	Lockwasher (5/16 dia.)
4	27556	1	Rotation Decal
5	203755	1	Instructional Decal
6	205112	1	Patent Number
7	202120	1	Name Plate
8	10575	4	Drive Screw
9	203756	1	Warning Decal

To Parts List

BASIC PUMP ASSEMBLY SIDE VIEW

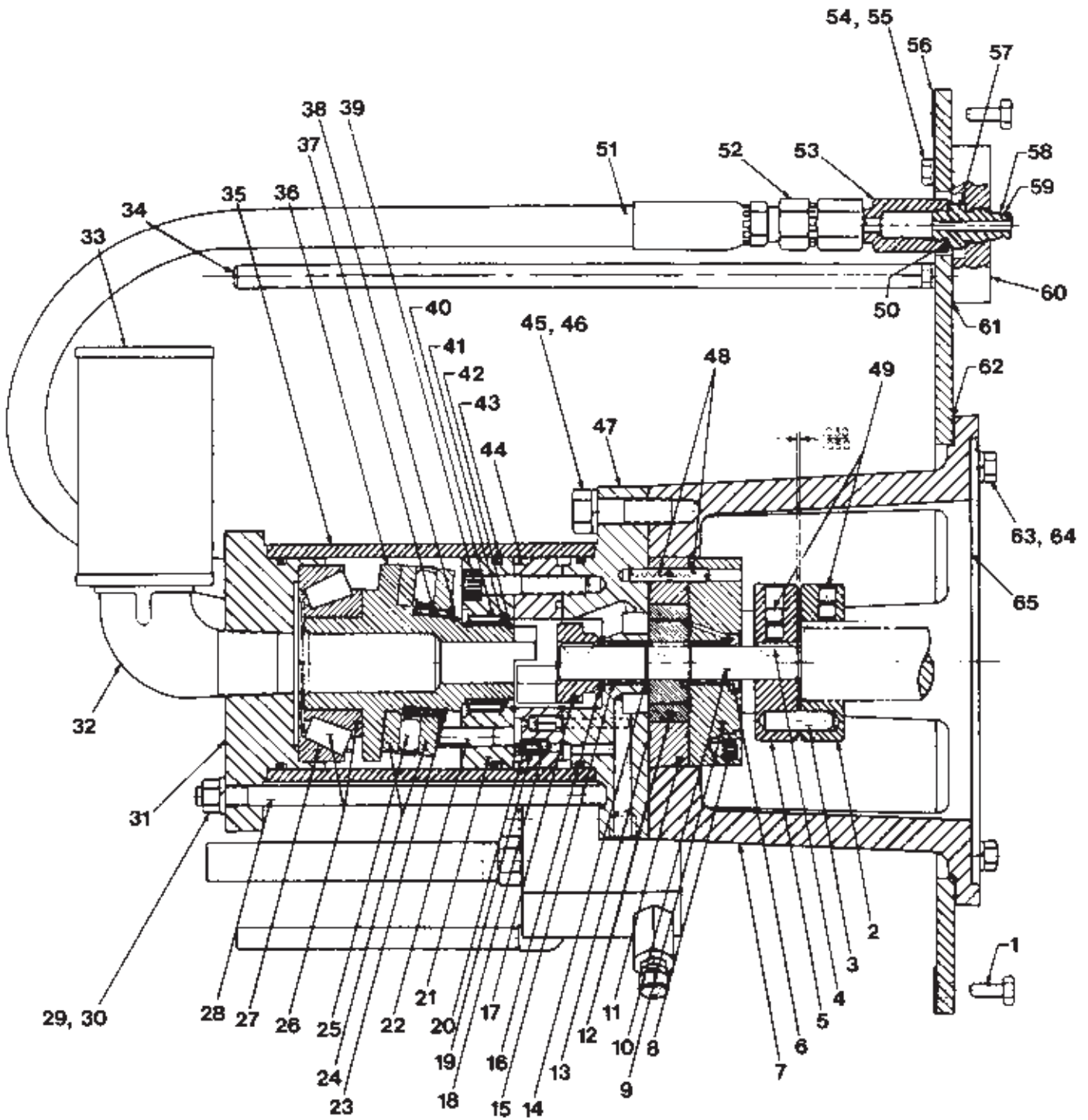

Item No.	Part No.	No. Req'd	Description	Item No.	Part No.	No. Req'd	Description
1	10009	20	Hex Hd. Cap Screw (1/4-20 x 3/4 Lg.)	35	37384	1	Pump Housing
2	37387	1	Coupling	36	51059	1	Angle Plate
3	203485	2	Nylon Pin	37	203476	1	Bushing
4	204537	3	Woodruff Key (1/8 x 5/8)	38	17566	1	Special Washer (Steel; 2-1/4 x 1.765 x 1/16 thk.)
5	37386	1	Coupling	39	11531	8	Soc. Hd. Cap Screw (3/8-16 x 2" Lg.; Cross torque in increments of 100 in. lbs. to 340/360 in. lbs. Note: Used on pumps built before 2-21-97.)
6	12194	1	Oil Seal Packing (1-1/8 x 5/8)		12866	8	Soc. Hd. Cap Screw (3/8-16 UNC x 2-1/4" Lg.; Cross torque in increments of 100 in. lbs. to 460/480 in. lbs. Note: Used on pumps built after 2-21-97.)
7	51089	1	Mounting Bracket				
8	10854	6	Soc. Hd. Cap Screw (1/4-20 x 1-3/4 Lg.; Cross torque to 80/100 in. lbs.)	40	17505	1	Needle Bearing
9	51064	1	Front End Plate	41	17504	1	Race Bearing
10	37376	1	Pump Shaft	42	17312	1	Retainer Ring (External; 1-3/8 Lg.)
11	42782	1	Eccentric (Ring)	43	11931	3	O-ring (4" x 3-3/4 x 1/8)
12	17313	1	Gerotor Set	44	42732	1	Valve Head
13	17315	2	O-ring (2-7/8 x 2-3/4 x 1/16)	45	10083	4	Hex Hd. Cap Screw (1/2-13 x 1-1/2 Lg.; Torque to 80/100 in. lbs.)
14	12178	2	Retainer Ring (External; 5/8 shaft)	46	10249	4	Spring Lockwasher (1/2)
15	15430	2	Needle Bearing (5/8 x 13/16 x 5/8 w.)	47	60415	1	Pump End Plate
16	17435	1	Thrust Washer (1" x 5/8 x 1/8)	48	17567	4	Spring Pin (1/4 x 3/4 Lg.)
17	37378	1	Drive Coupling	49	10141	4	Set Screw (5/16-18 x 5/16 Lg.)
18	10374	16	Steel Ball (7/32 dia.)	50	10261	1	Soft Copper Washer
19	203477	16	Ball Guide	51	303838	1	Hydraulic Hose (3/8 I.D. x 27" Lg.)
20	17319	16	Compression Spring (1/8 O.D. x 1/2 Lg.)	52	17582	1	Swivel Fitting
21	43313	1	Pump Barrel	53	21566	1	Valve Body
22	204578	8	Piston (.399 dia.; NOTE: Install piston with 6° angle toward angle plate.)	54	10009	4	Hex. Hd. Cap Screw (1/4-20 x 3/4 Lg.)
23	14368	1	Retainer Ring (External; 1-3/4 shaft)	55	10245	4	Spring Lockwasher (1/4)
24	17316	2	Race Bearing	56	42779	1	Reservoir Gasket
25	17317	1	Thrust Bearing	57	201817	1	Valve Connector
26	17311	1	Cone Bearing	58	11863	1	Backup Washer (PTFE)
27	17318	1	Race Bearing (Cup)	59	10268	1	O-ring (1/2 x 3/8 x 1/16)
28	203542	4	Tie Rod	60	43110	1	Valve Mounting Block
29	10204	4	Steel Nut (3/8-16; Cross torque in increments of 50 in. lbs. to 170/180 in. lbs.)	61	200395	1	Gasket
30	10247	4	Spring Lockwasher (3/8)	62	42796	1	Gasket (Mounting Bracket)
31	42737	1	End Cap	63	10032	4	Hex. Hd. Cap Screw (5/16-18 x 1" Lg.)
32	10706	1	90° Pipe Elbow	64	10246	4	Spring Lockwasher (5/16)
33	17491	1	Filter	65	42757	1	Gasket (Electric Motor)
34	204265	1	Drain Tube				



BASIC PUMP ASSEMBLY BOTTOM VIEW

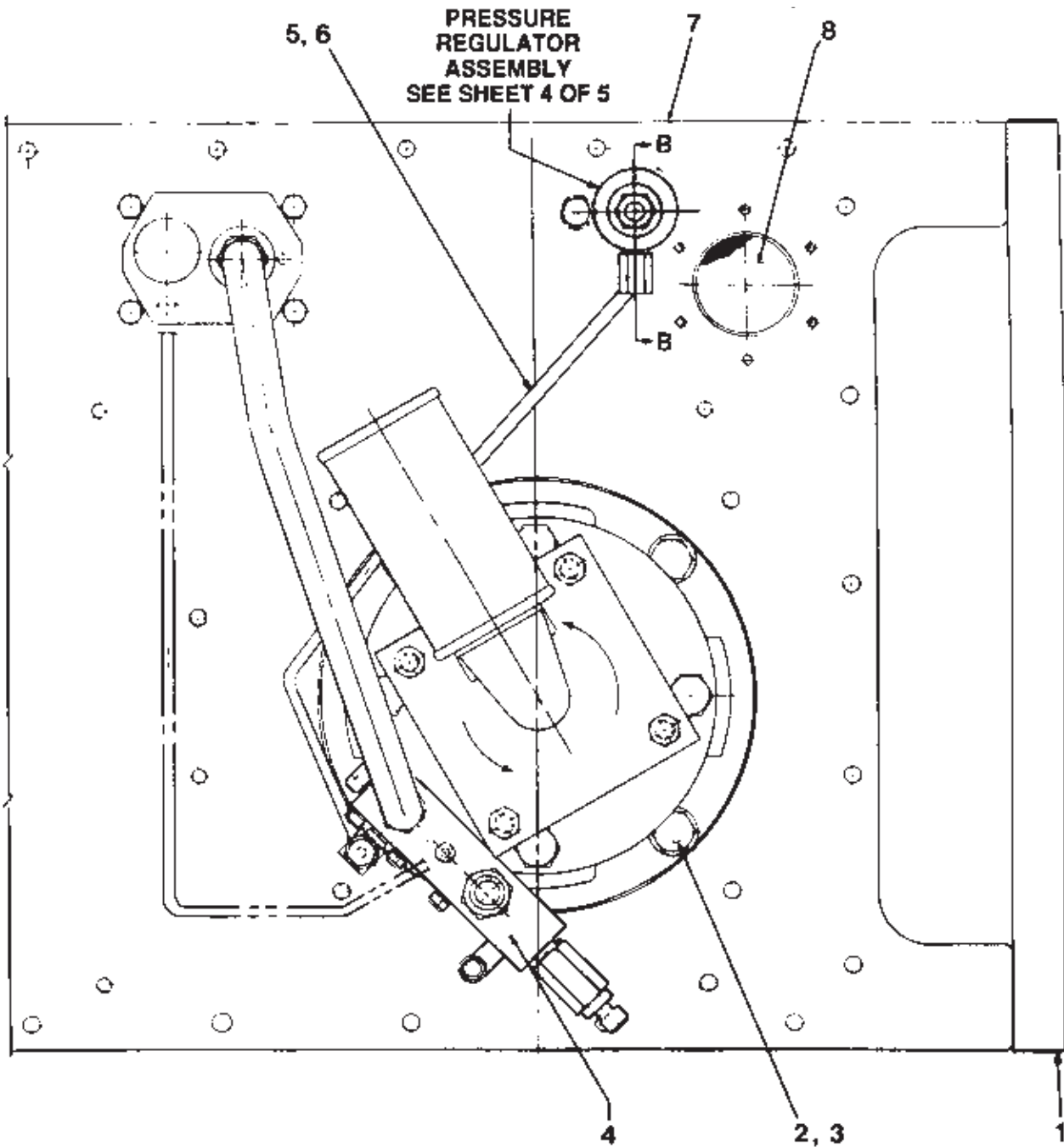

Item No.	Part No.	No. Req'd	Description
1	12126	4	Square Insert
2	11623	4	Hex. Hd. Cap Screw (1/2-13 x 1-1/4 Lg.)
3	10249	4	Spring Lockwasher (1/2)
4	42795	1	Unloading Valve Assembly (See back sheet 4 of 7)
5	43647	1	Oil Line (Pressure Regulator)
6	12696	1	Straight Connector
7	51098WH2	1	Cover Plate Weldment
8	13167	1	Filter/Breather Assembly

PRESSURE REGULATOR ASSEMBLY

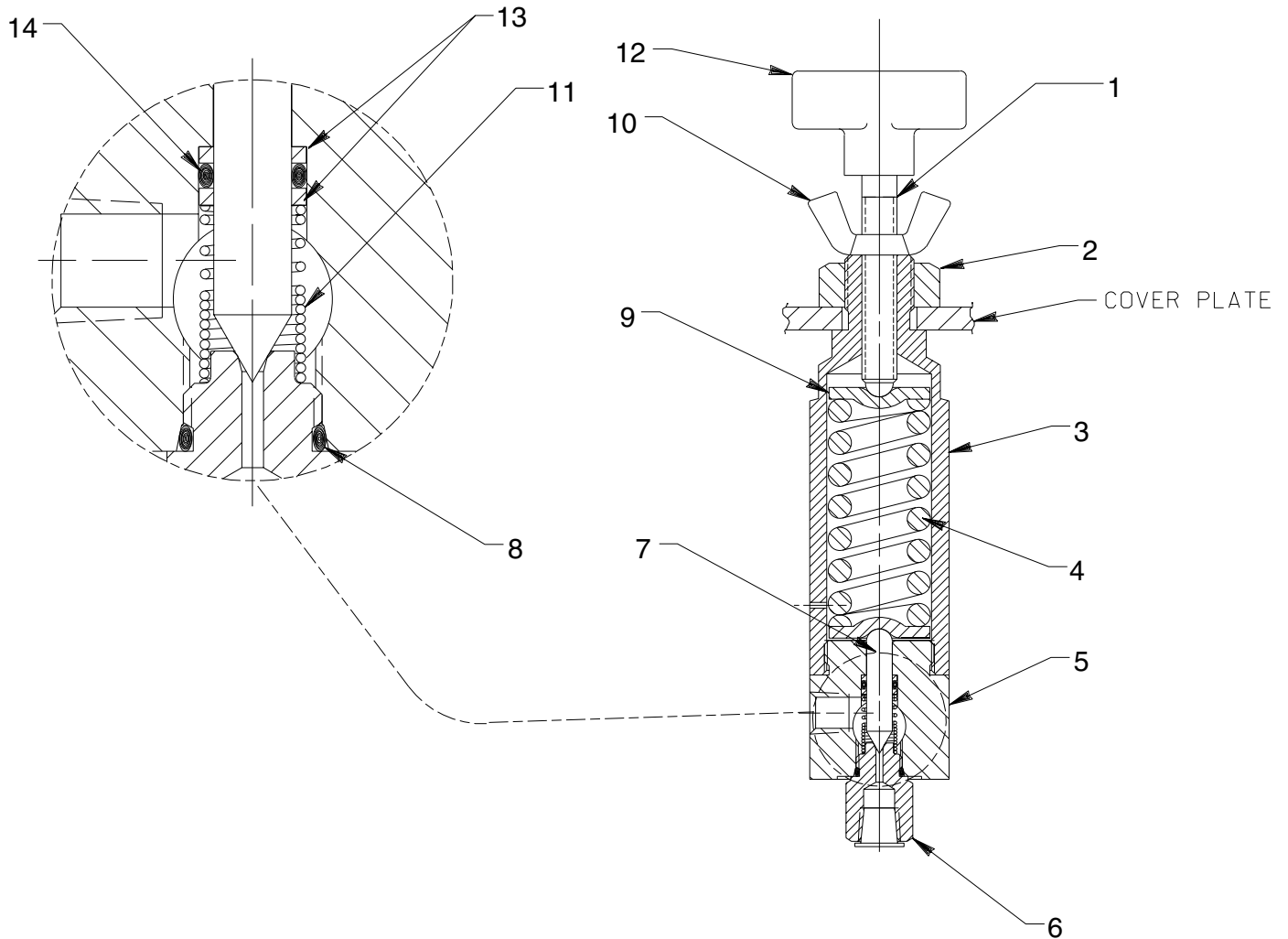

Item No.	Part No.	No. Req'd	Description
1	215721	1	Stem (NOTE: Assemble to Tee Knob [Item #12] with Loctite No. 242 or equivalent.)
2	10396	1	Jam Nut (3/4-16)
3	309077	1	Spring Housing
4	215429	1	Compression Spring (1.100 O.D. x 2-1/2 Lg.)
5	47648	1	Regulator Body
6	309078	1	Seat Fitting
7	309079	1	Poppet
8	13755	1	O-ring (9/16 x 13/32 x 5/64)
9	215428	2	Spring Retainer (Grease pocket before assembling. [Both sides])
10	215683	1	Wing Nut
11	215431	1	Compression Spring (NOTE: Assemble closed coils of spring form towards seat fitting [Item #6].)
12	215693	1	Tee Knob
13	215430	2	Backup Washer (3/8 x 9/32 x 3/64)
14	10266	1	O-ring (3/8 x 1/4 x 1/16)

PARTS INCLUDED BUT NOT SHOWN

11127	2	Plug (3/8 NPTF Male)
10427	1	Plug (1/8 NPTF Male Hex)
10475	1	90° Tube Elbow
14463	1	Pipe Nipple (5-1/2 Lg.)

Sheet No. 4 of 5

Rev. 5 Date: 25 May 2012

UNLOADING VALVE ASSEMBLY

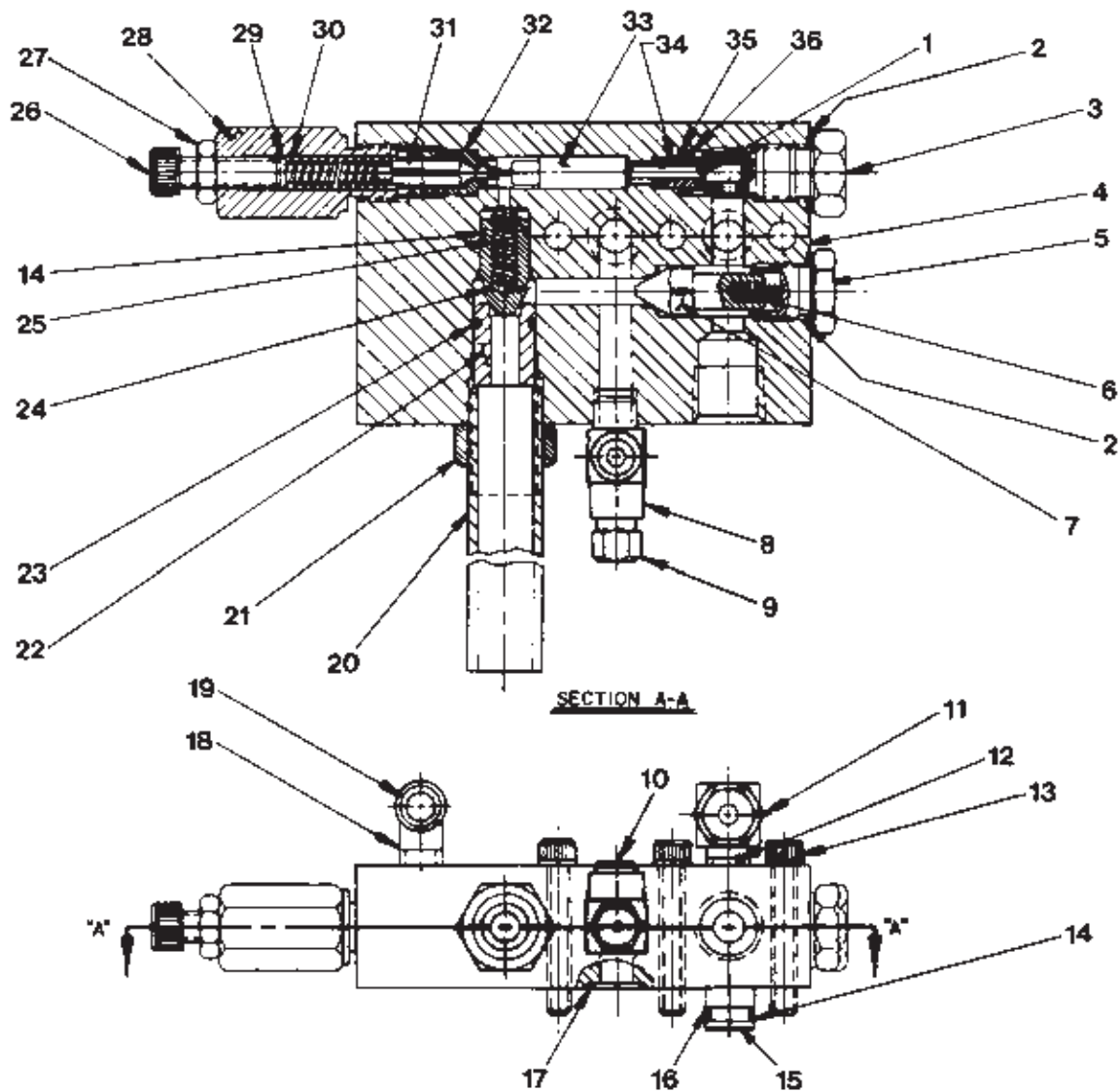

Item No.	Part No.	No. Req'd	Description
1	12149	1	Dowel Pin (1/8 dia. x 3/4 Lg.)
2	10261	2	Copper Washer (19/32 x 3/4 x 1/32)
3	37430	1	Adapter (Torque to 35/40 ft. lbs.)
4	60414	1	Valve Body
5	205394	1	Valve Plug (Torque to 35/40 ft. lbs.)
6	15141	1	Compression Spring (.180 O.D. x 5/8 Lg.)
7	205393	1	Poppet (Seat at assembly)
8	18969	1	Tee Fitting
9	306957	1	Air Bleed Valve
10	10427	1	Pipe Plug (1/8 NPTF)
11	21278	1	Relief Valve Assembly (Set at 10,100/10,700 PSI)
12	24702	1	Tee
13	10022	3	Soc. Hd. Cap Screw (1/4-20 x 1-1/2 Lg.)
14	10268	3	O-ring (1/2 x 3/8 x 1/16)
15	21094	1	Bushing
16	11863	2	PTFE Backup Washer
17	12098	1	O-ring (9/16 x 7/16 x 1/16)
18	13229	1	90° Elbow

Item No.	Part No.	No. Req'd	Description
19	14463	1	Drain Tube
20	203620	1	Drain Tube
21	10396	1	Jam Nut (3/4-16)
22	203621	1	Bushing
23	10301	1	O-ring (5/8 x 1/2 x 1/16)
24	37423	1	Poppet (Seat at assembly)
25	11221	1	Compression Spring (.240 O.D. x 1" Lg.)
26	11013	1	Soc. Hd. Cap Screw (5/16-18 x 1" Lg.)
27	10385	1	Jam Nut (5/16-18)
28	36545	1	Fitting (Torque to 25/30 ft. lbs.)
29	16528	1	Spacer
30	17413	1	Compression Spring
31	203541	1	Poppet (Seat at assembly)
32	37427	1	Guide
33	203540	1	Plunger Assembly
34	17414	1	Bushing (1/16 x 1/8 x 1/2 Lg.)
35	15085	1	PTFE Backup Washer (7/16 x 5/16 x 1/16)
36	10267	1	O-ring (7/16 x 5/16 x 1/16)

MOTOR CONTROL ASSEMBLY

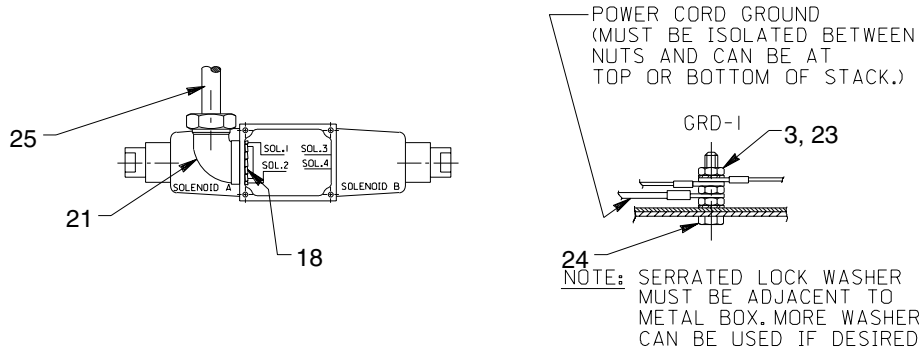
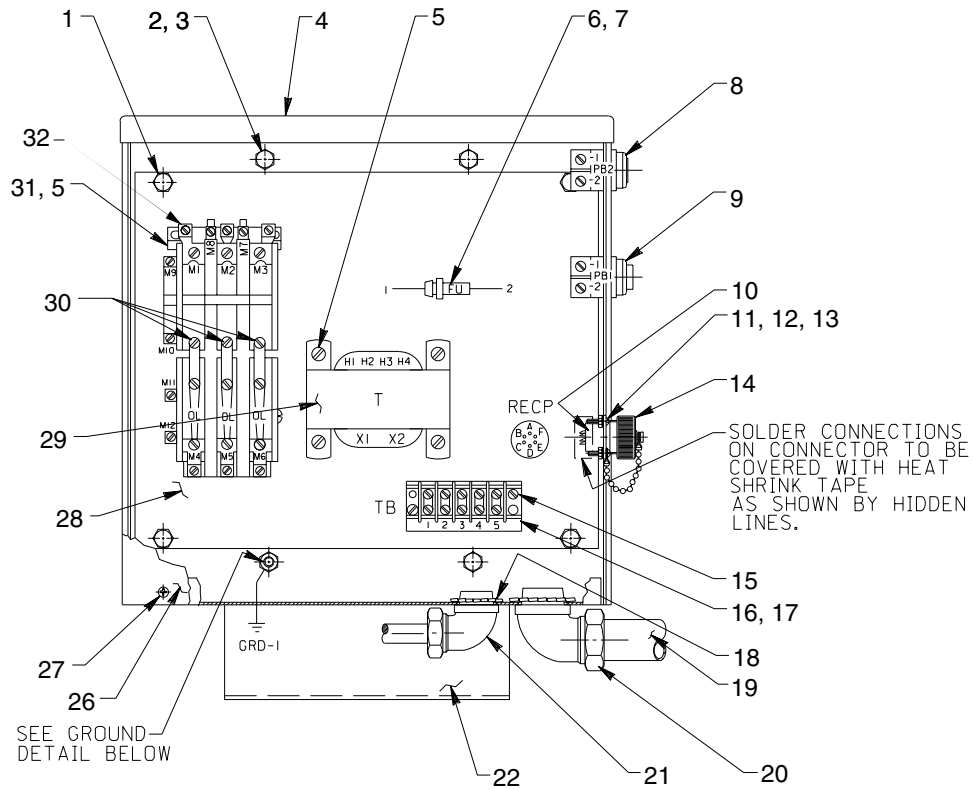

Item No.	Part No.	No. Req'd	Description
1	10004	4	Hex. Hd. Cap Screw (1/4-20 UNC x 3/8 Lg.)
2	10005	3	Hex. Hd. Cap Screw (1/4-20 UNC x 1/2 Lg.)
3	12809	6	Locknut (1/4-20)
4	420240WH2	1	Electrical Control Box
5	13063	6	Pan Hd. Machine Screw (#10-24 x 1/4 Lg.)
6	16887	1	Fuse Holder
7	214110	1	Fuse (1.5 amp)
8	39282	1	Pushbutton Switch (Green)
9	39283	1	Pushbutton Switch (Red)
10	350269	1	Pin Connector Receptacle
11	11835	4	Machine Screw (#4-1/2 Lg.)
12	15907	4	Washer
13	10194	4	Nut (#4)
14	250438	1	Protective Cap
15	11426	2	Machine Screw (#6-32 x 1/2 Lg.)
16	17842	1	Imprinted Marker Strip
17	17841	1	Terminal Block

Item No.	Part No.	No. Req'd	Description
18	11362	2	Conduit Locknut
19	13340	1.5 ft.	Sealtite Conduit (3/4)
20	13343	2	90° Elbow Fitting
21	17840	2	90° Elbow Fitting
22	51099WH2	1	Mounting Bracket
23	11351	2	Lockwasher (1/4)
24	10017	1	Hex. Hd. Cap Screw (1/4-20 UNC x 1-1/2 Lg.)
25	15424	1 ft.	Conduit (3/8 Flex Steel)
26	51107WH2	1	Electrical Box Cover
27	13534	2	Self-tapping Screw
28	51106OR9	1	Stand-off Plate
29	38962	1	Transformer
30	16641-69	3	Heaters
31	420241	1	Starter
32	11141	2	Screw (6-20 x 3/8 Lg.)

Note: Shaded areas reflect last revision(s) made to this form.

ELECTRICAL SCHEMATIC

50 Hz. MOTOR CONNECTIONS

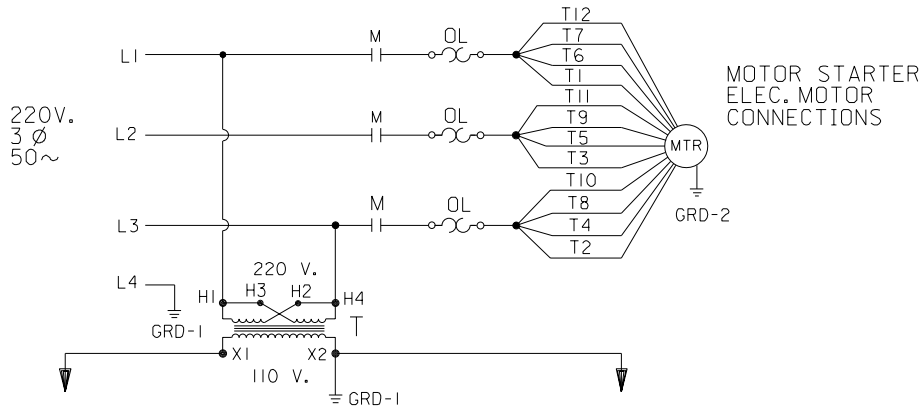

60 Hz. MOTOR CONNECTIONS

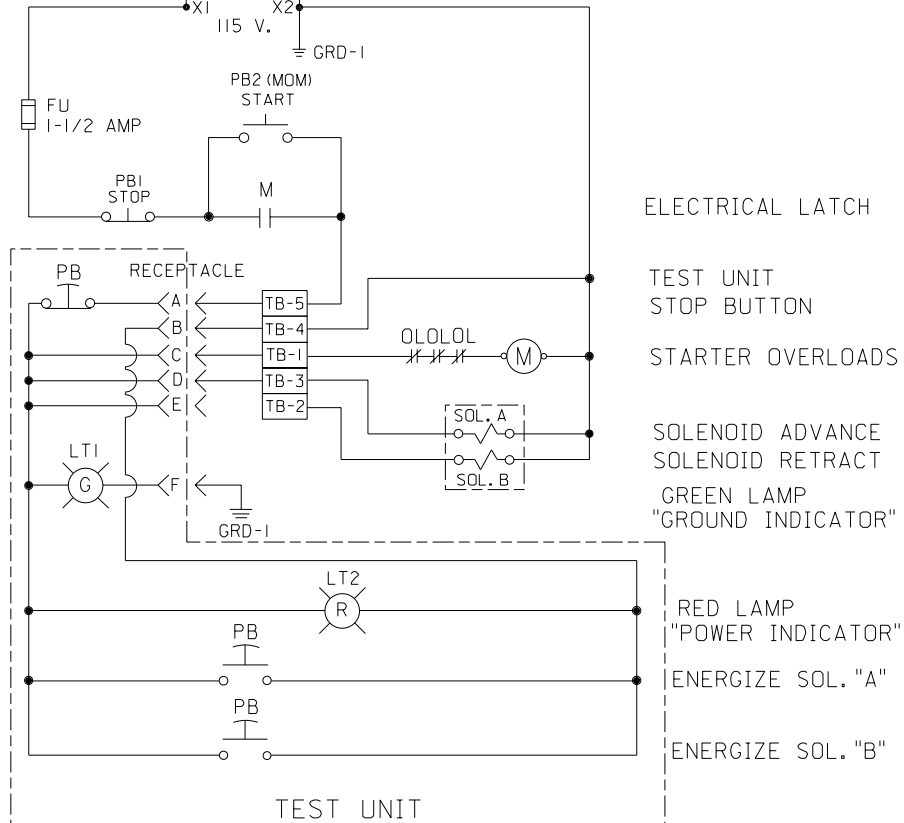
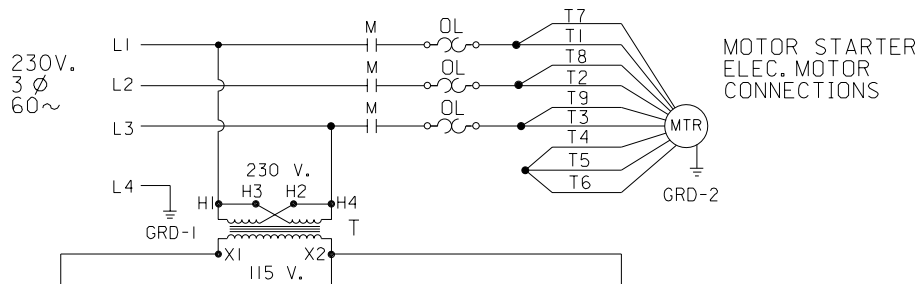

****NOTE:**

1. MOTOR MUST BE WIRED FOR CLOCKWISE ROTATION VIEWED FROM LEAD END.
2. FOR PROPER MOTOR VOLTAGE CONNECTION AND ROTATION SEE CONNECTION INFORMATION SUPPLIED WITH MOTOR.